



# HRL-0200-1 HEATLESS DESICCANT AIR DRYER GENERAL ARRANGEMENT

TOLERANCES UNLESS  
OTHERWISE SPECIFIED:

- FRACTIONS = ± 1/4 "
- ANGLES = ± 3°
- INCHES = ± 1/2 "
- FINISH = 250

THE SPECIFICATIONS AND DRAWINGS DISCLOSED HEREIN ARE THE SOLE PROPERTY OF ALTEC AIR, AND SHALL NOT BE COPIED OR USED AS THE BASIS FOR SALE OR MANUFACTURE WITHOUT EXPRESS WRITTEN PERMISSION.

### REVISION LOG

REV.	ECO.	DESCRIPTION	DATE	APPROVED
H	1026	PRODUCTION UPDATES	10/1/2020	WS

DRAWING NO. **AT20-429** REV. **H**

DRAWN: MR DATE: 2/25/2015  
 CHECKED: DATE: SCALE: N/A SHEET: 1 OF 2

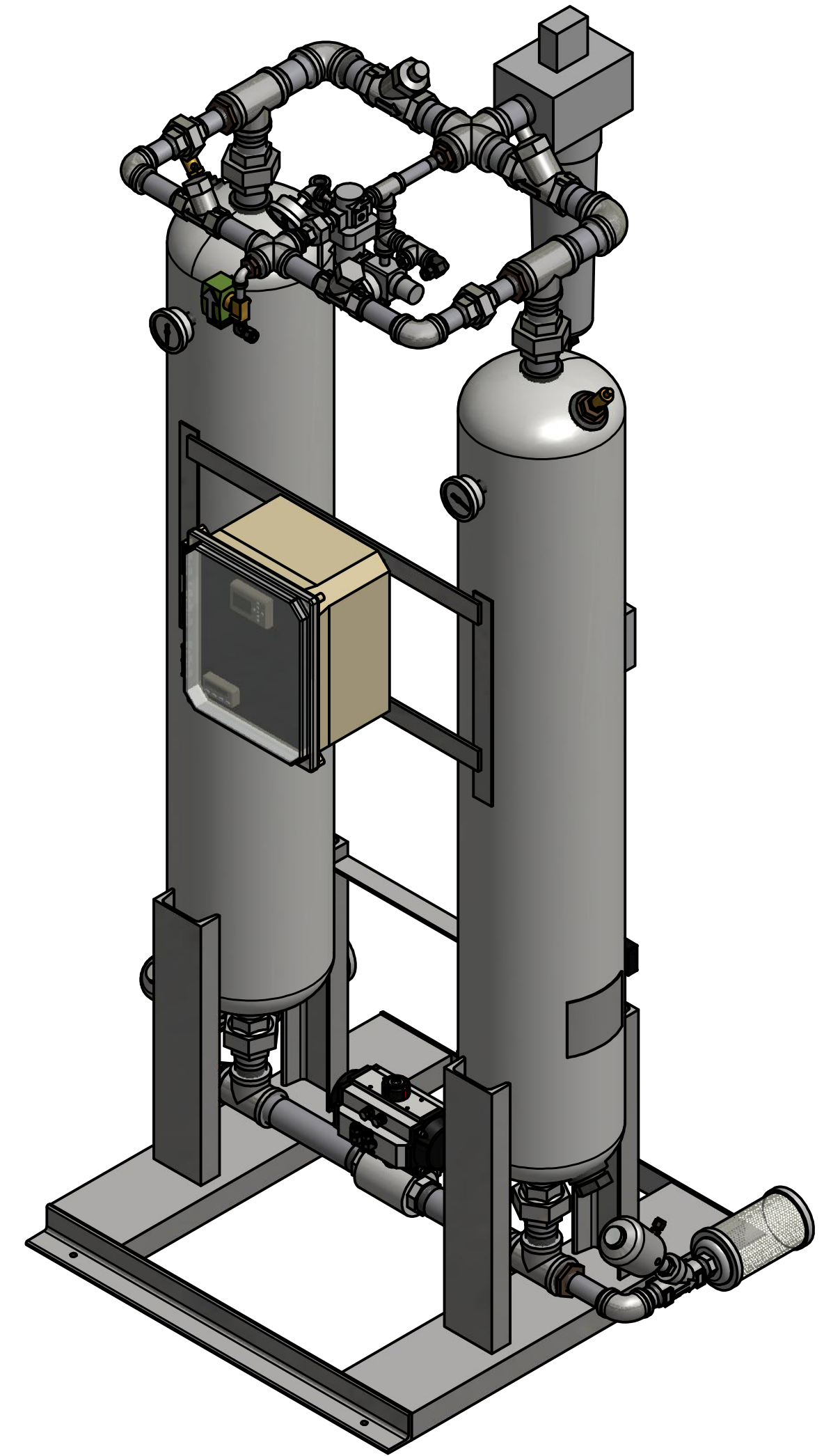
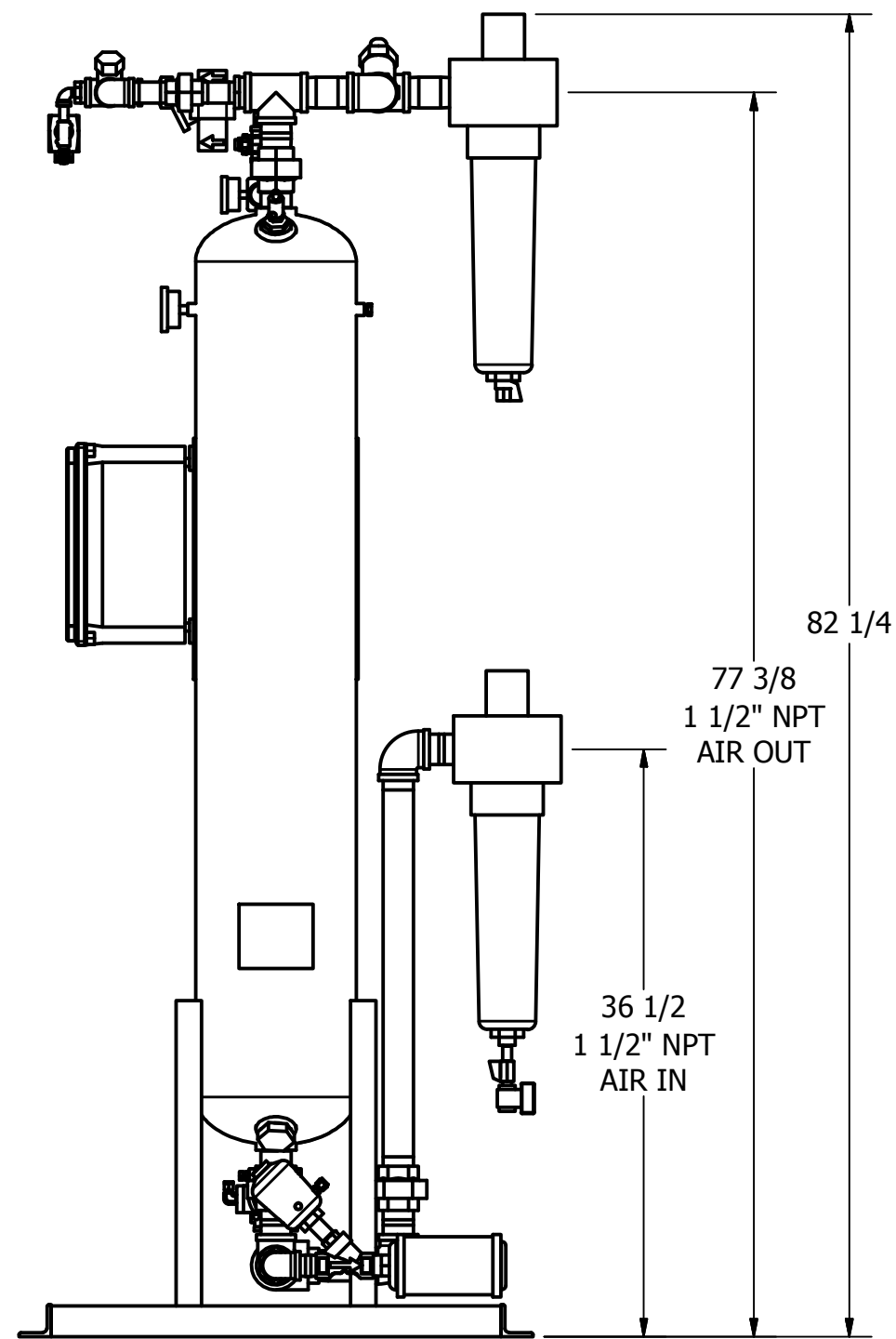
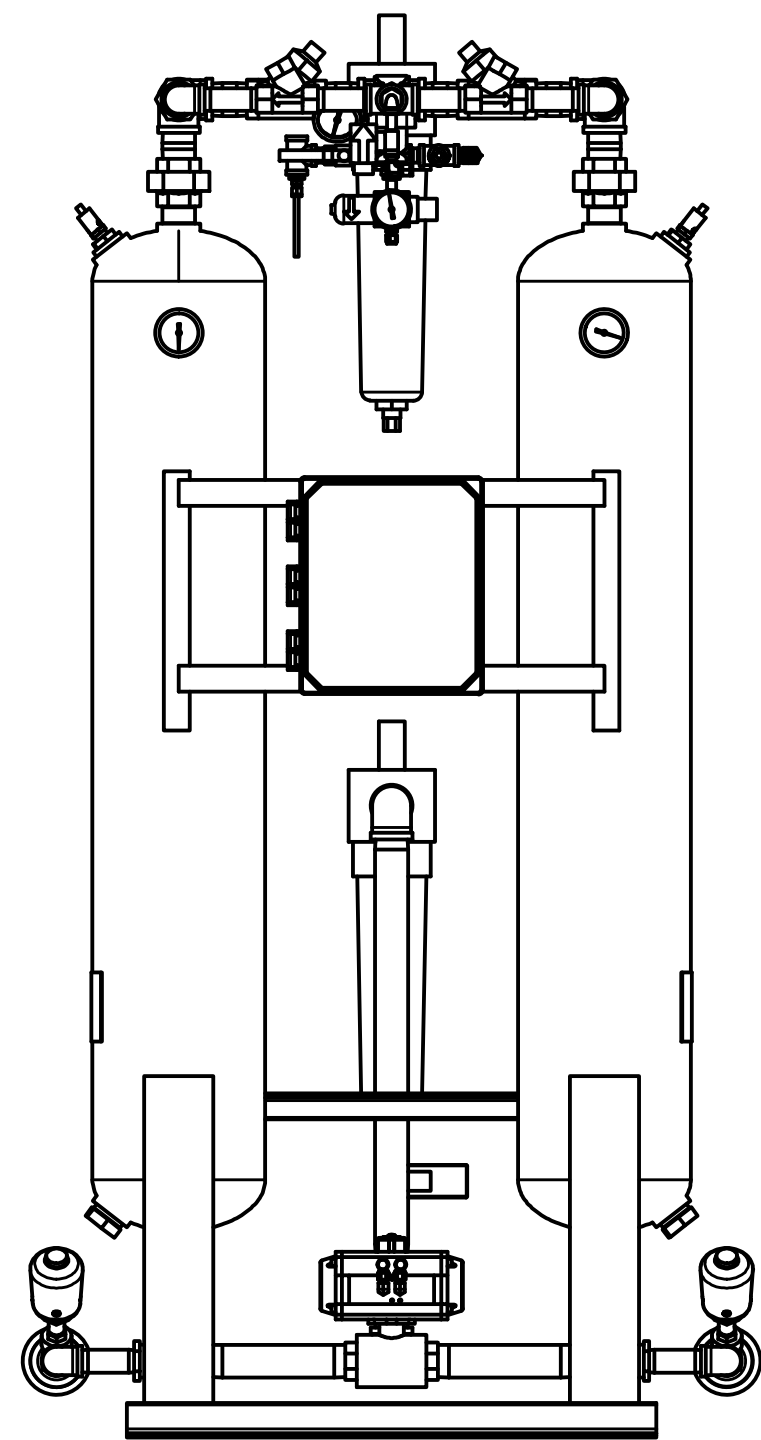
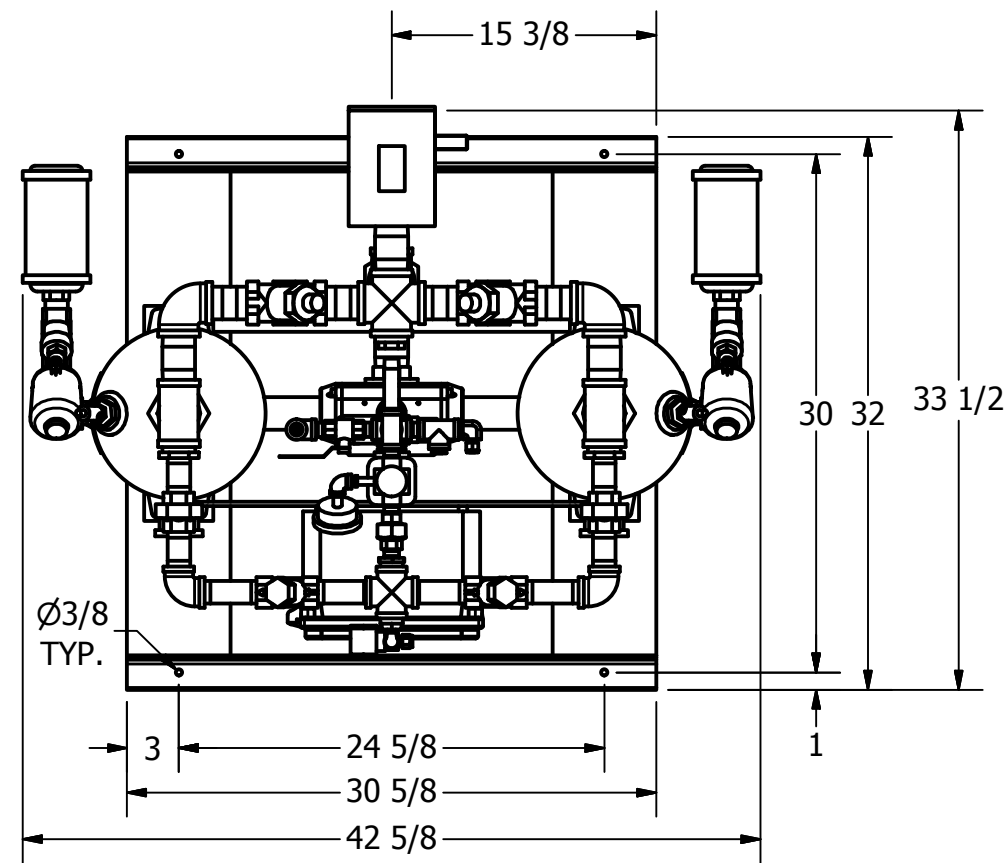

**PRELIMINARY**



# HRL-0200-1 HEATLESS DESICCANT AIR DRYER GENERAL ARRANGEMENT

TOLERANCES UNLESS  
OTHERWISE SPECIFIED:

FRACTIONS = ± 1/4 "  
ANGLES = ± 3°  
INCHES = ± 1/2 "  
FINISH = 250

THE SPECIFICATIONS AND DRAWINGS DISCLOSED HEREIN ARE THE SOLE PROPERTY OF ALTEC AIR, AND SHALL NOT BE COPIED OR USED AS THE BASIS FOR SALE OR MANUFACTURE WITHOUT EXPRESS WRITTEN PERMISSION.

### REVISION LOG

REV.	ECO.	DESCRIPTION	DATE	APPROVED
H	1026	PRODUCTION UPDATES	10/1/2020	WS

DRAWING NO.

AT20-429

REV.  
H

DRAWN: MR  
CHECKED:

DATE: 2/25/2015  
DATE:

SCALE: N/A

SHEET: 2 OF 2

### PARTS LIST

ITEM	QTY	DESCRIPTION
1	2	CHECK VALVE, PURGE
2	1	PRESSURE REGULATOR, PURGE
3	1	PRESSURE GAUGE, PURGE
4	2	CHECK VALVE, OUTLET
5	1	PRESSURE REGULATOR, CONTROL
6	1	PRESSURE GAUGE, CONTROL
7	1	DEW POINT MONITOR (OPTIONAL)
8	1	SOLENOID, REPRESS
9	1	MOISTURE INDICATOR
10	2	RELIEF VALVE, TANK
11	2	PRESSURE GAUGE, TANK
12	1	3 WAY BALL VALVE, INLET
13	1	PARTICULATE AFTER-FILTER
14	1	COALESCER PRE-FILTER
15	1	TIMED DRAIN
16	2	ANGLE BODY VALVE, EXHAUST
17	2	MUFFLER, EXHAUST
18	220 LBS	DESICCANT

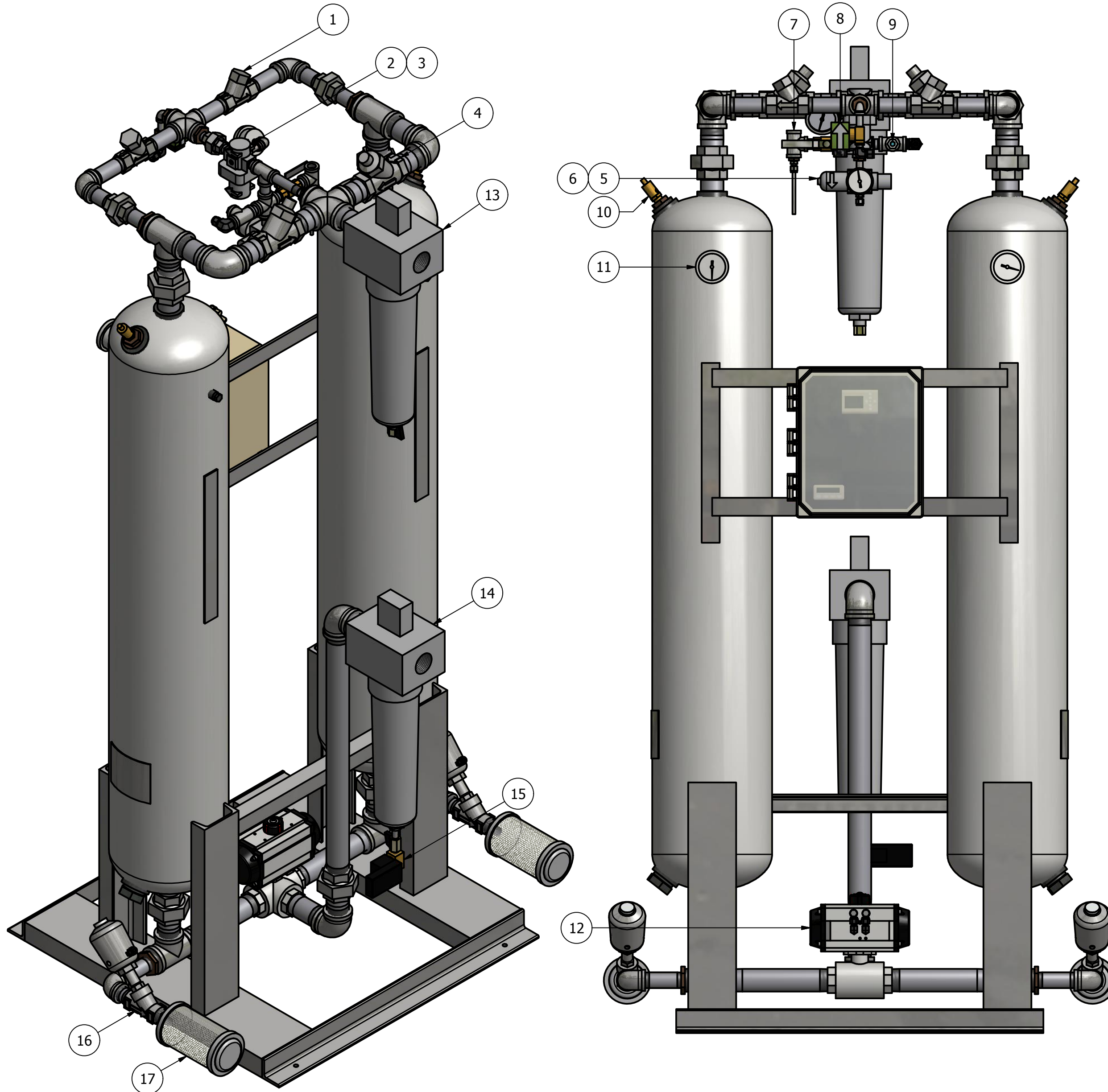

**PRELIMINARY**